

---

# Auger-Matic Feeding Systems

*Installation Guide*

Instr. # 11-00-0673 09/03

*For the following systems:*

*FLUXX*

*Big PAN*

*UniGROW 360*

*Cycle 14*

*Cyclone*

*Orange One*

*Rapid Rooster*

*Rooster*

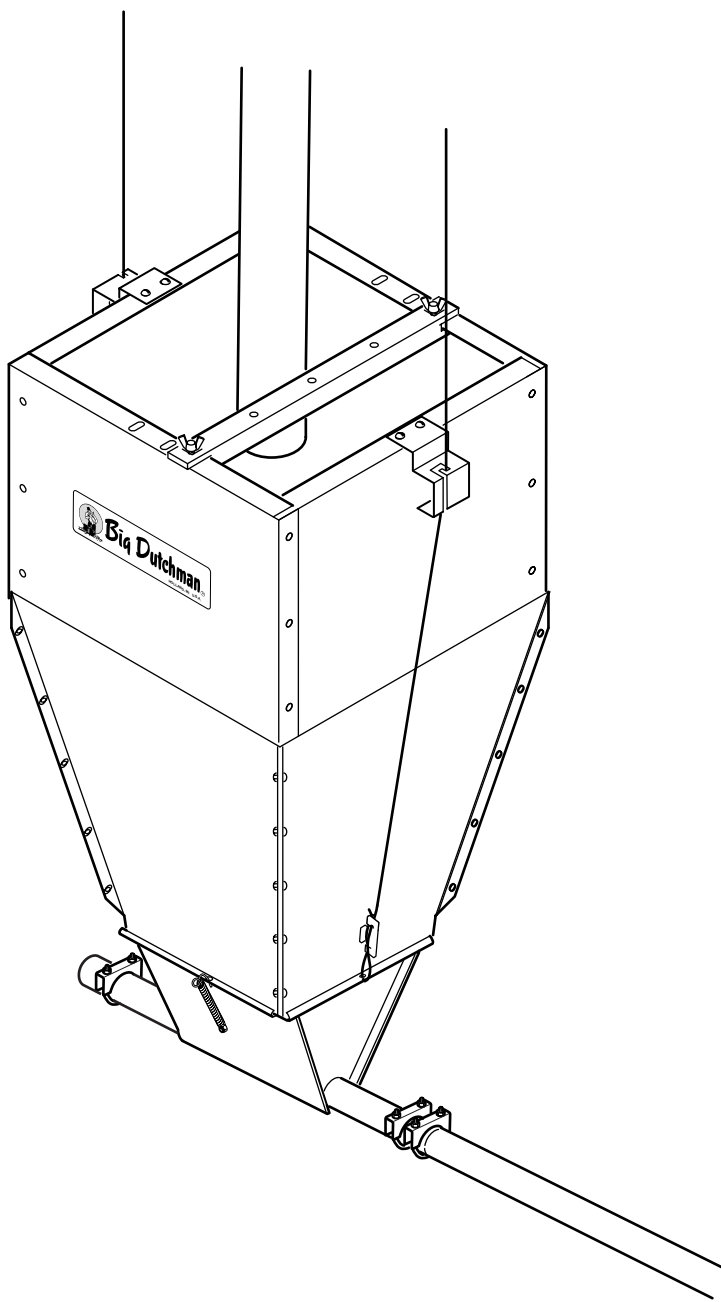

**Big Dutchman**

# Notes, Warnings, and Cautions



This manual contains **Notes**, **Warnings** and **Cautions** in addition to the assembly instructions.

**Notes:** Provide additional comments to help with installation and set up.



**CAUTIONS:** Provide notification of situations that can cause damage to machinery and tools.



**WARNINGS!** Provide alerts to situations that can cause personal injury or death.

Please take the time to read and understand this manual before beginning assembly.

**CAREFULLY FOLLOW THE SAFETY AND OPERATING INSTRUCTIONS in this manual.**

Observe the following precautions when working on or near the machinery:

- Understand the limitations and hazards associated with operating this equipment before using.
- Wear appropriate eye protection when assembling and using this equipment .
- Do not wear loose clothing, jewelry, etc.
- Keep sleeves rolled above the elbows.
- Confine long hair.
- Always wear approved protective footwear.

**MAKE SURE ALL PERSONNEL UNDERSTAND THE POTENTIAL DANGER** of someone getting too close or trying to make repairs or adjustments while the machine is running. This equipment has several **AREAS WHERE INJURIES COULD OCCUR IF GUARDS OR COVERS ARE REMOVED.**

**KEEP ALL COVERS AND GUARDS IN PLACE WHILE EQUIPMENT IS IN OPERATION.**

Observe the following precautions when servicing the machinery:

- Do not remove guards except when performing maintenance.
- Do not operate the machine with guards or covers removed.
- When performing maintenance or repairs make sure the local control switch is **OFF** and the main power control panel is **OFF** and tagged **“DO NOT OPERATE.”**
- Make all adjustments with the power **OFF**.
- **NEVER** reach into the machine while the system is operating, keep hands out of the machine chain and belt areas. Keep all guards and covers in place when power is on.
- Work carefully and give the work you are doing your undivided attention. Do not look away, talk or play around. Careless acts can cause **SERIOUS INJURY.**

# Table Of Contents

|   |    |
|---|----|
| Tools Required .....  | 3  |
| Introduction .....  | 4  |
| Before You Begin .....  | 4  |
| System Overview .....   | 5  |
| Installation Procedures .....   | 6  |
| <i>Installing the Hopper</i> .....  | 6  |
| <i>Installing the Drive Unit</i> .....                                    | 10 |
| <i>Installing the Intermediate Control Pan &amp; Pan Assemblies</i> ..... | 13 |
| <i>Installing the Auger Tube</i> .....                                    | 14 |
| <i>Suspending the Feeding Line</i> .....                                  | 16 |
| <i>Installing the Auger</i> .....   | 17 |
| <i>Brazing the Auger</i> .....  | 19 |
| <i>Installing Anti-Perch Equipment</i> .....                              | 20 |
| Finishing, Testing and Start-up Operation .....                           | 22 |

## Tools Required

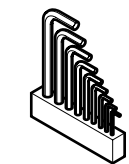

Hex Wrenches

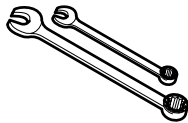

Wrenches

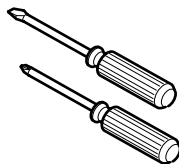

Screwdrivers

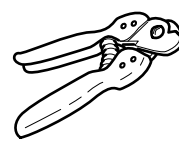

Cable Cutters



Chalk Line



Needle Nosed Pliers

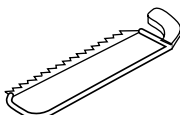

Hacksaw



Hammer

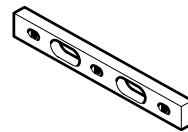

24" Level

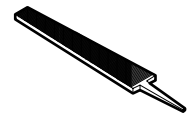

File

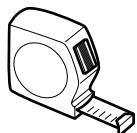

Tape Measure

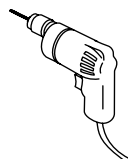

Electric Drill



Torch

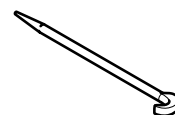

Drift Pin

# Introduction

Big Dutchman Auger Feeding Systems are designed to work in cooperation with Big Dutchman Suspension Equipment. This manual contains instructions for assembling and installing all Big Dutchman Auger Feeding Systems.

When used with the Big Dutchman Suspension Equipment, the auger feeding line can be raised or lowered to suit your needs. Because of the recent standardization of Big Dutchman's Auger Feeding Systems, many of the auger feeder components have been consolidated. Each of these consolidated parts will be explained in this manual.

## About This Manual

This manual will help you to install the following universal components of the Big Dutchman Auger Feeding Systems:

- Hopper, Extension and Feed Drop Positioner
- Drive Unit
- Control Pan
- Auger and Auger Tube

Please refer to your separate Pan Assembly Instruction Manual for instructions on how to assemble and install your particular pan assemblies.

## About Big Dutchman

To find out more about Big Dutchman products and services, please contact us using one of the following methods:

|                     |  |
|---------------------|--|
| On-Line Information | <a href="http://www.bigdutchmanusa.com">www.bigdutchmanusa.com</a>   |
| E-Mail              | <a href="mailto:bigd@bigdutchmanusa.com">bigd@bigdutchmanusa.com</a> |
| Fax                 | (616) 392-6188   |
| Telephone           | (616) 392-5981   |
| Mail                | P.O. Box 1017<br>Holland, Michigan<br>49422-1017 USA                 |

---

# Before You Begin

Before you begin to assemble your Auger Feeding System, you will need to do some preliminary work. The following tips will aid you in the installation of your System:

- Read through the manual completely before you begin to install your Auger Feeding System.
- Install the suspension equipment before installing your Feeding System (refer to the Suspension Equipment Installation Guide).
- Determine the exact location of the feeder hoppers before positioning the feed bins and installing the fill system.
- The entire equipment layout should be drawn to scale on graph paper before you install the equipment.

All wiring must be done by a qualified, licensed electrician, in accordance with federal, state, and local codes. Big Dutchman reserves the right to change product specifications and designs without notice or obligation.

# System Overview

Pictured below are the two configurations of a Big Dutchman Auger Feeding Line. In the one-way feeding line, the hopper is located at one end of the line and a single drive unit is located at the opposite end. In the two-way feeding line, the hopper is located in the middle of the building. There are two drive units for a two-way feeding line; one unit is on each end of the line.

Big Dutchman offers two types of drive units with which you can power your Auger Feeding System. With either a one-way or a two-way system, you can use a belt drive unit or a gear drive unit. Instructions for installing each of these styles are given in this guide.

Each drive unit is operated by a control pan. The control pan is the last pan in the line before the drive unit, and it controls when the drive unit starts and stops.

If you plan to have partial-house brooding, you will need to install an intermediate control pan.

Suspend your Auger Feeding System from the ceiling with Suspension Equipment. Please refer to your Big Dutchman Suspension Equipment Installation Guide for instructions on how to install this system.

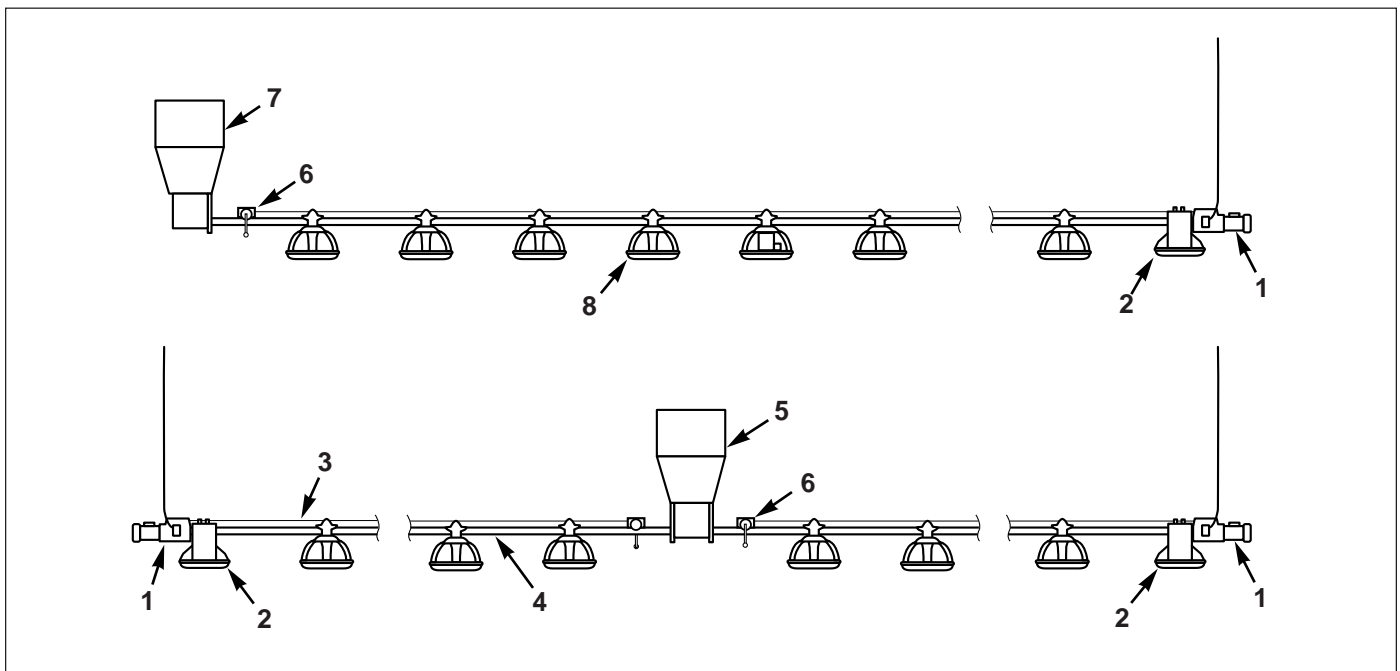

1. Drive Unit (Gear or Belt)
2. Control Pan
3. Anti-Perch Wire
4. Auger Tube

5. Two-Way Hopper
6. Flood Control Winch (UniGROW 360 Only)
7. One-Way Hopper
8. Feeder Pan

# Installation Procedures

## Installing the Hopper

### Assembly

1. Place the hopper in the necessary location.

*If you have a one-way hopper:*

- Place the hopper at the end of the house.

*If you have a two-way hopper:*

- Place the hopper at the center of the house.

2. Assemble the hopper extension.

- Align the holes of the extension sides with a drift pin. Install the screws and nuts.

Do not tighten the screws completely until all screws and nuts are in place and the extension is square.

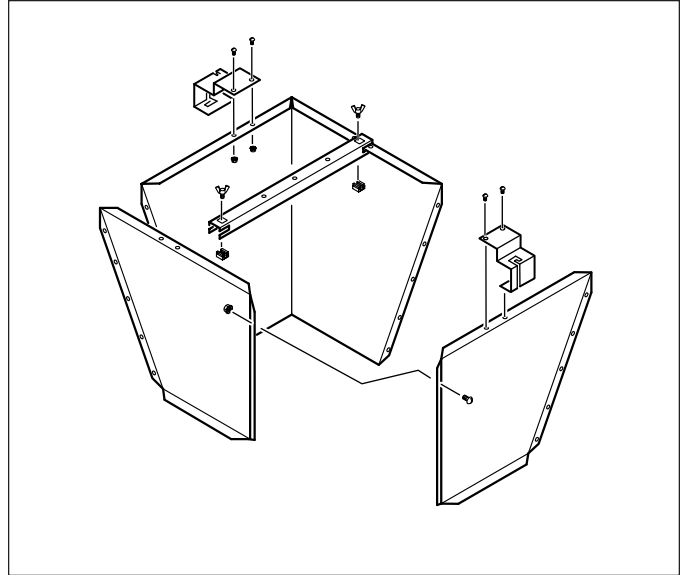

**Assemble Hopper Extension.**

### Installation

Mount the hopper extension to the hopper.

1. Insert the extension under the wide lip of the hopper.
2. Lower the extension as shown.
3. Slide the extension under the opposite lip of the hopper.
4. Attach the spring-hook to secure the extension to the hopper.

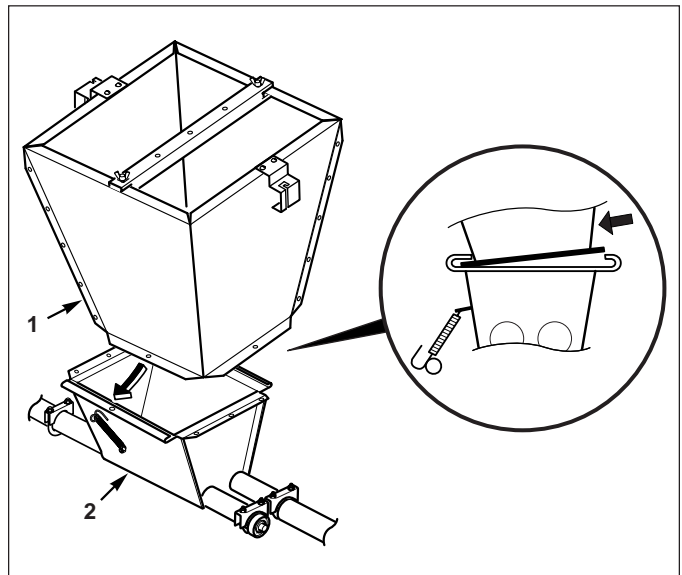

**STEP 1: Insert extension under the wide lip of the hopper.**  
**1. Hopper Extension**  
**2. Hopper**

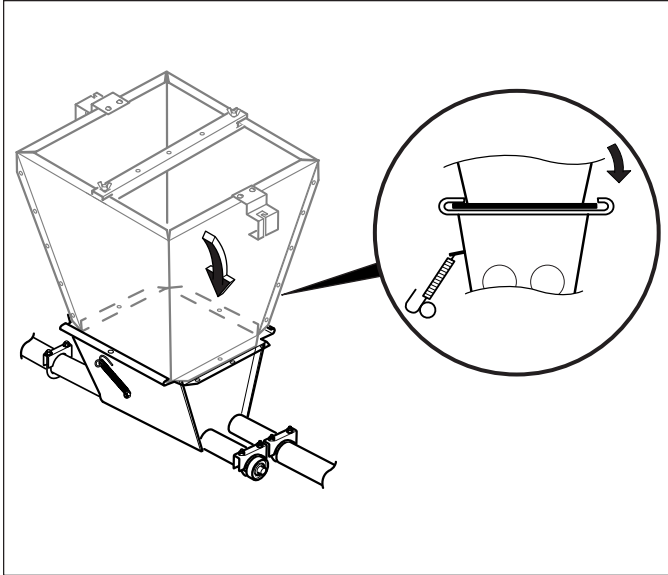

**STEP 2:** Lower Extension as shown

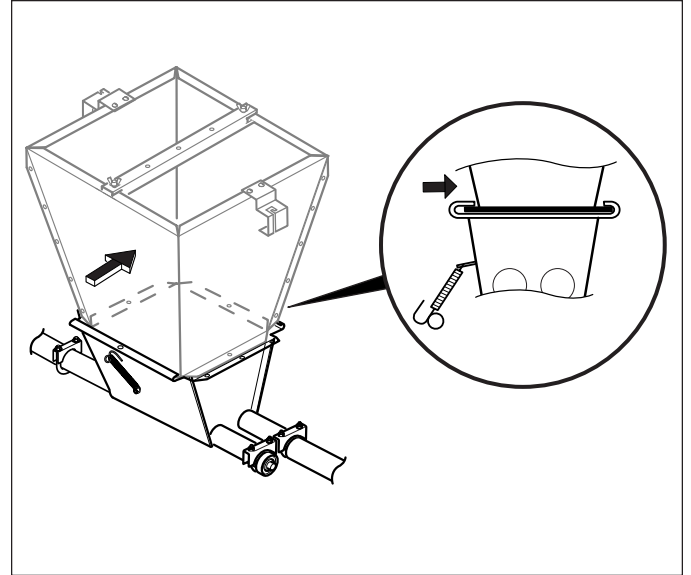

**STEP 3:** Slide Extension under the opposite lip of the Hopper.

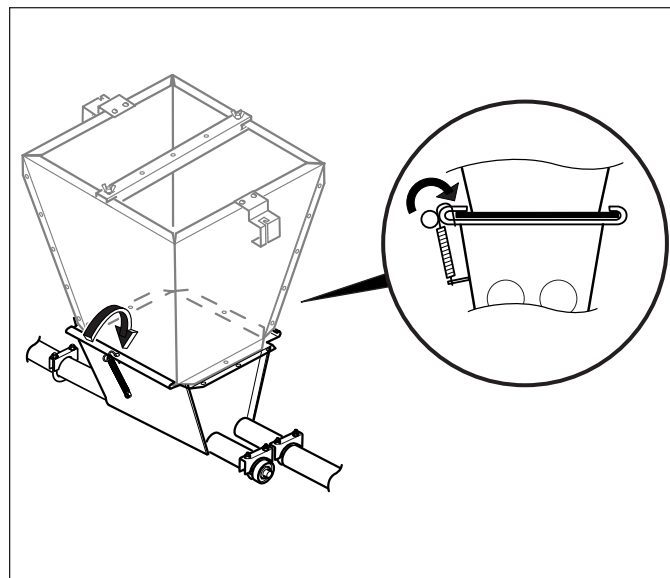

**STEP 4:** Attach the Spring-hook to secure the Extension to the Hopper.

**Suspend the hopper:**

1. Attach the S-hook to the hole in the front of the hopper or install a hanger on to the hopper tube.
  - Insert the open end of the S-hook into the hopper; reserve the closed end for the drop cable.
2. Route the drop cable through a cable lock and then through the S-hook or hanger.
3. Fasten the end of the cable to the cable lock.
4. Route the drop cable through the cable guide on the end of the hopper.
5. Repeat with the other cable on the opposite end of the hopper.

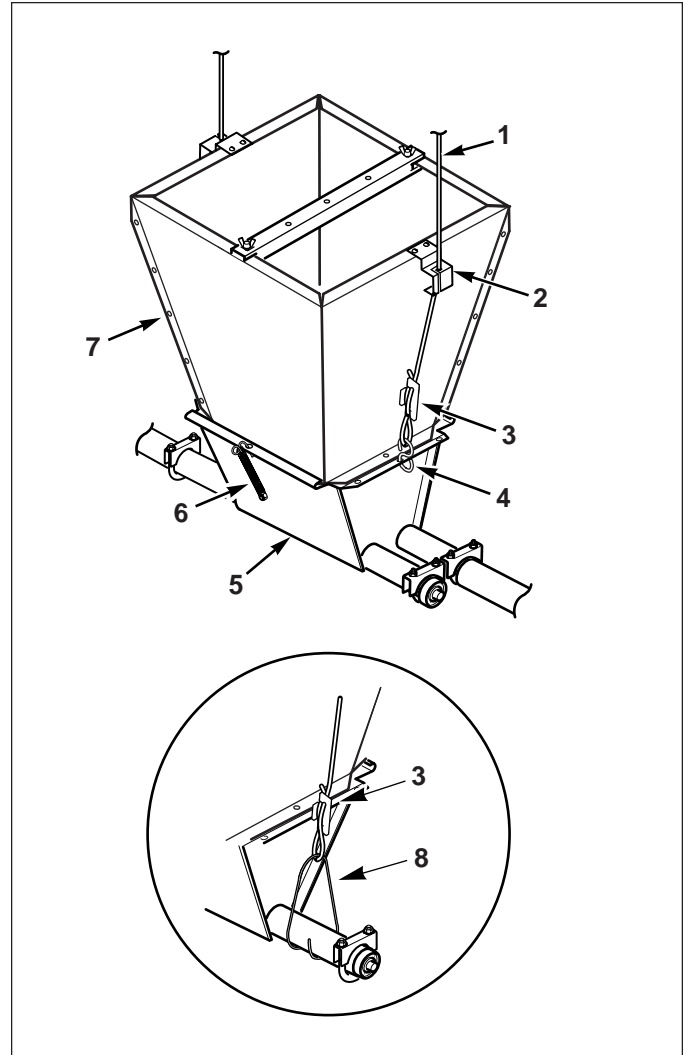

**Suspend the hopper using an S-hook or a hanger.**

- |                                    |                     |
|------------------------------------|---------------------|
| 1. Drop Cable                      | 5. Hopper           |
| 2. Route Cable through Cable Guide | 6. Spring Hook      |
| 3. Cable Lock                      | 7. Hopper Extension |
| 4. S-Hook                          | 8. Hanger           |



**Install the feed drop positioner.**



**IMPORTANT:** The location of the Feed Drop Positioner is critical to the performance of your auger feeding system.

*If you have a one-way hopper,*

- Place the Positioner so that the feed drop tube enters the hopper on the opposite end from the where the hopper control switch will be.

*If you have a two-way hopper,*

- Place the Positioner so that the feed drop tube enters the hopper at the center.

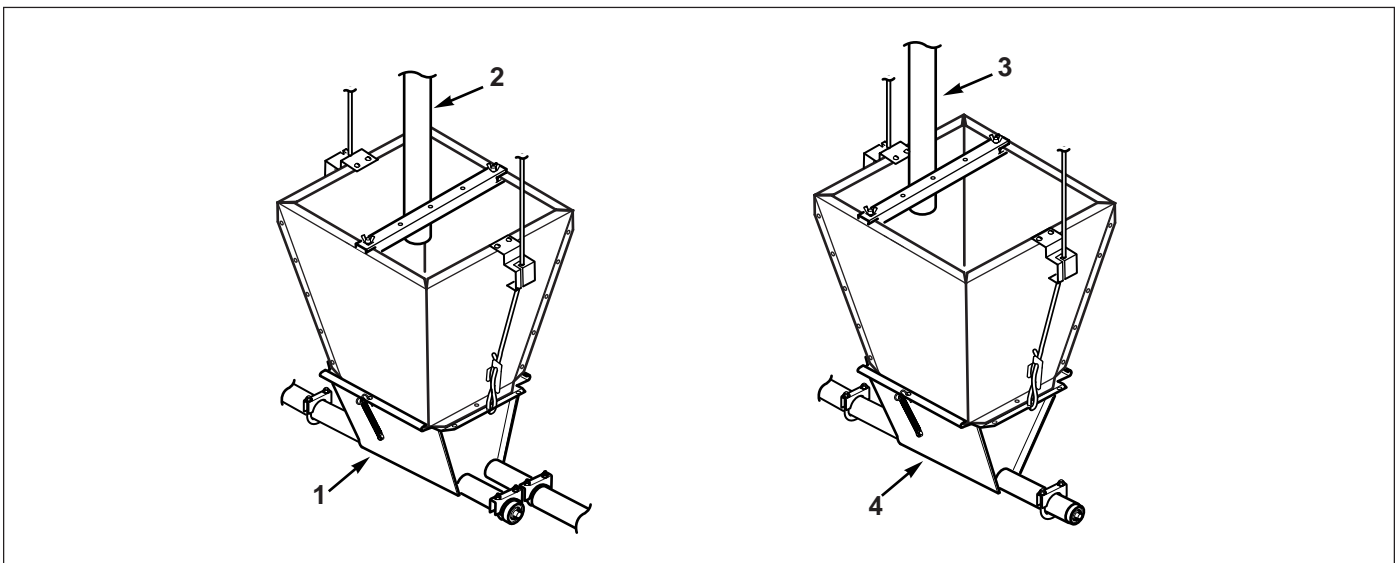

**Install the feed drop positioner so that the feed drop tube will enter the hopper at the correct location.**

- |   |  |
|---|--|
| <p>1. Two-way Hopper</p> <p>2. Feed Drop Tube (enters the hopper in the center)</p> | <p>3. Feed Drop Tube (enters the hopper on the end opposite the control switch)</p> <p>4. One-way Hopper</p> |
|---|--|

## Installing the Drive Unit

On a one-way system the drive unit is at the opposite end of the building from the hopper. On a two-way system the hopper is in the middle of the building and one drive unit is at each end.

### Gear Drive Unit

#### Assembly

1. Attach the arbor to the drive unit.
  - Secure the arbor assembly to the reducer of the drive unit with the clevis pin, washer, and cotter pin.

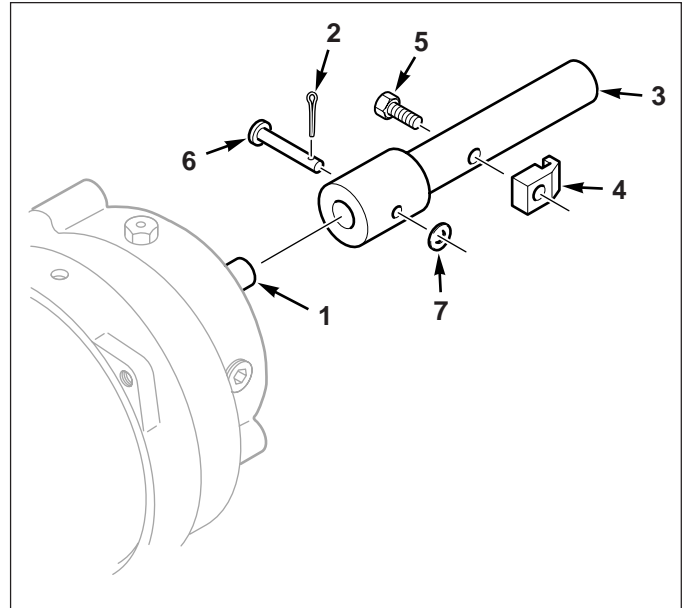

Attach the arbor to the drive unit.

- |                |                     |
|----------------|---------------------|
| 1. Drive Shaft | 4. Auger Clamp      |
| 2. Cotter Pin  | 5. Auger Clamp Bolt |
| 3. Arbor       | 6. Clevis Pin       |
|                | 7. Washer           |

#### Installation

1. Attach the drive unit to the control pan.
  - Insert the arbor through the hole in the control pan.
  - Secure the pieces together with bolts and washers through the four mounting holes.
2. Attach the drop cable for the drive unit to the top of the gear reducer.
3. Secure the cable with a cable lock.

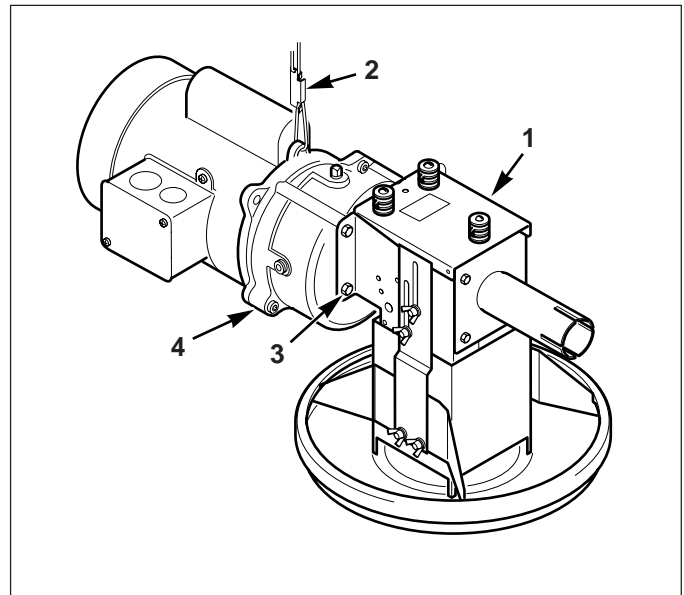

Attach the drive unit to the control pan.

- |                         |                   |
|-------------------------|-------------------|
| 1. Control Pan Assembly | 3. Mounting Bolts |
| 2. Cable Lock           | 4. Gear Reducer   |

## Belt Drive Unit

### Assembly

1. Mount the motor to the frame of the belt drive unit.
  - Use the bolts on the motor mount (located on the underside of the frame), but do not tighten the bolts at this time.
2. Install the Belt Guard Back onto the frame of the belt drive unit.
3. Attach the small sheave on the motor shaft. Install the square key and tighten the setscrew.
4. Install the large sheave on the drive shaft. Install the square key and setscrew.

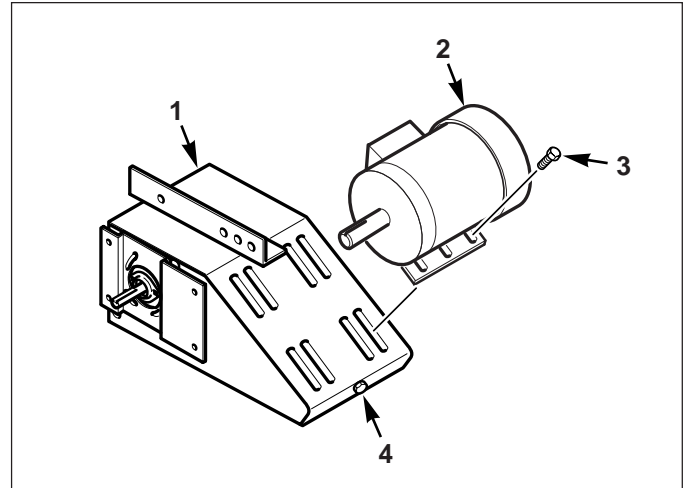

*Install the Motor on the frame of the Belt Drive Unit.*

- |          |                               |
|----------|-------------------------------|
| 1. Frame | 3. Bolt                       |
| 2. Motor | 4. Motor Mount Adjusting Bolt |

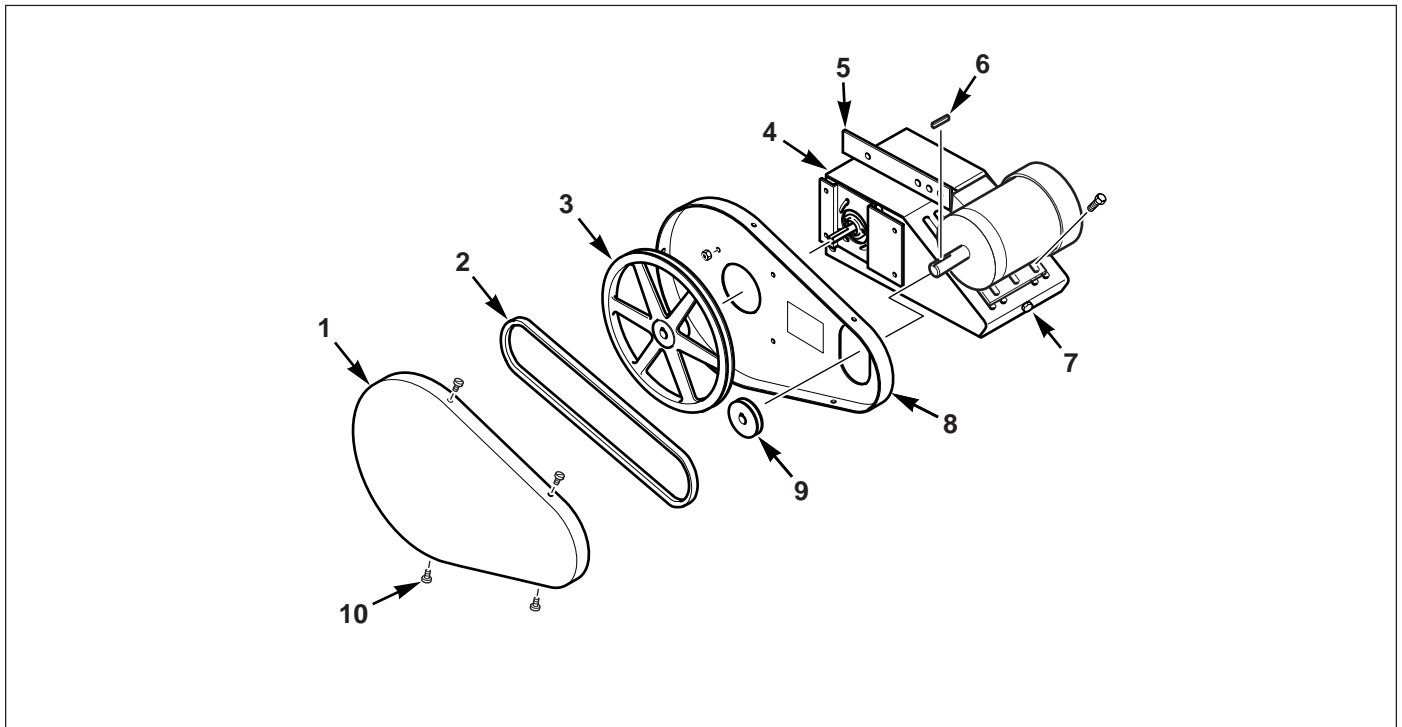

*Mount the belt and belt cover to the Belt Drive Unit.*

- |                       |                               |
|-----------------------|-------------------------------|
| 1. Belt Guard Cover   | 6. Square Key                 |
| 2. V-Belt             | 7. Motor Mount Adjusting Bolt |
| 3. Large Sheave       | 8. Belt Guard Back            |
| 4. Frame              | 9. Small Sheave               |
| 5. Suspension Bracket | 10. Belt Guard Screw          |



**IMPORTANT:** Make sure that you properly align the small and large sheaves. If the sheaves are not properly aligned, the belt will quickly wear down.

5. Slip the V-Belt onto the sheaves.
  - Adjust the position of the motor mount until the belt is tight.
  - Tighten the bolts on the motor mount.
6. Install the belt cover and secure it in place with the provided screws.



**WARNING!** Never operate the drive unit without the belt cover in place.

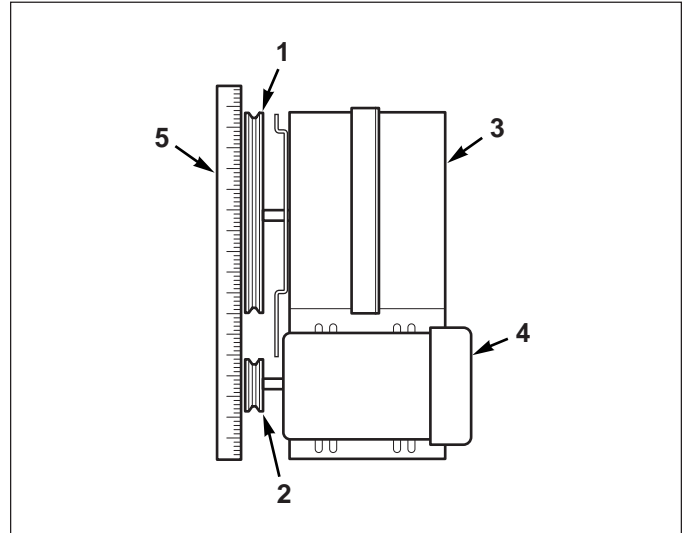

*Align the two sheaves of the belt drive unit.*

- |                 |                     |
|-----------------|---------------------|
| 1. Large Sheave | 3. Belt Drive Frame |
| 2. Small Sheave | 4. Motor            |
|                 | 5. Straight Edge    |

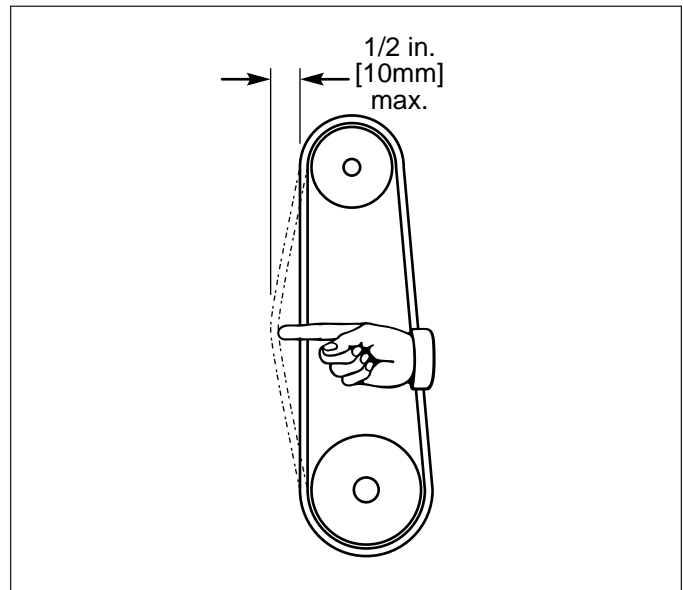

*After aligning the sheaves, tighten the V-Belt as shown.*

# Installing the Intermediate Control Pan

## Pan Assemblies

Assembly instructions vary by the type of pan used. Please refer to the appropriate Pan Assembly Instruction Sheet for pan installation procedures.

## Intermediate Control Pan

1. Determine where any intermediate control pans will be located. Remove the pan assembly at these locations.
2. Enlarge the tube holes for the intermediate control pan, 2 pans in front of the control pan and one pan after the control pan (4 places ONLY) .



**CAUTION: Do not cut beyond half the diameter of the tube.**

- Do not remove the tube tabs.
- Cut both sides of the tube approximately one third of the way around the tube.
- Break off the cutout by bending it back and forth with pliers.
- File the tube hole to remove all sharp edges and burrs from it.

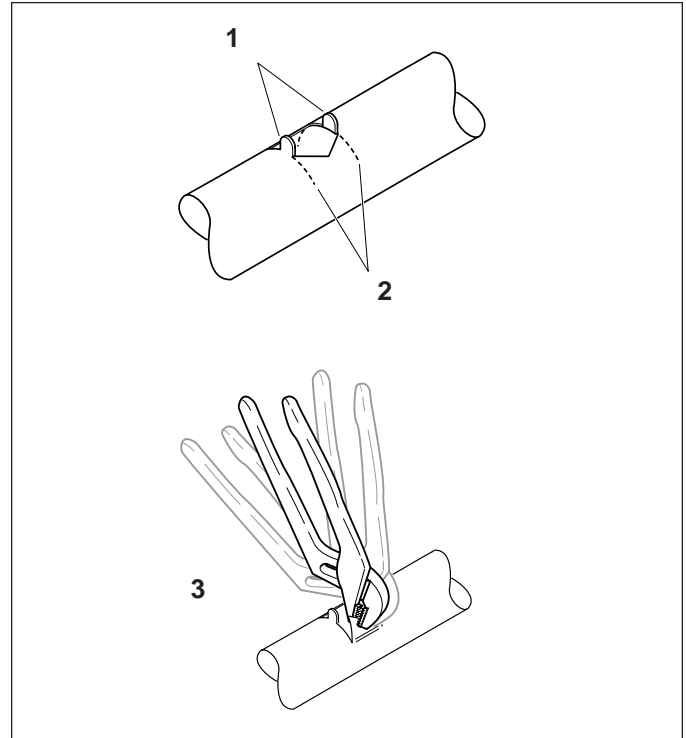

**Enlarge the feed drop hole for the intermediate control pan.**

1. Do not remove tabs
2. Cut along dashed line
3. Use pliers to break off the cutout by bending back and forth.

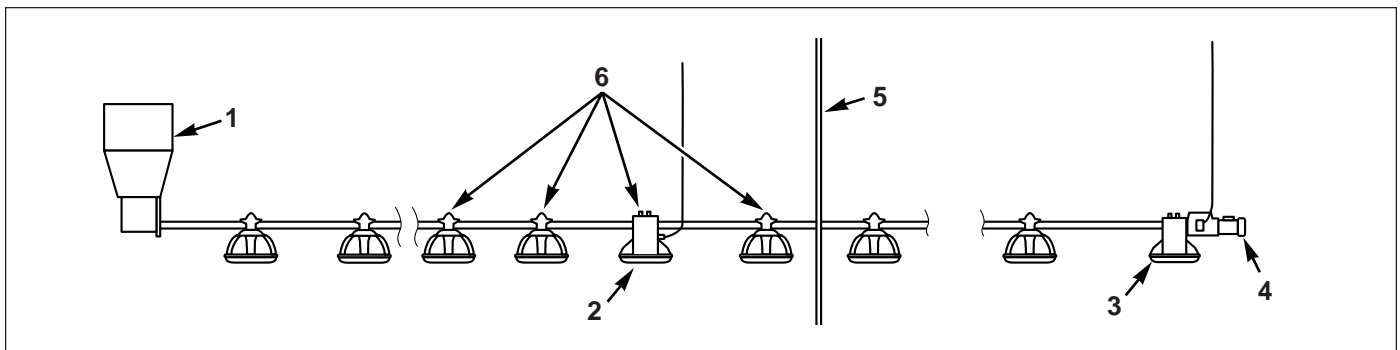

**Install an intermediate control pan second from the partition (curtain) when partial-house brooding.**

- |                             |                |                                  |
|-----------------------------|----------------|----------------------------------|
| 1. Hopper                   | 3. Control Pan | 5. Partition (Curtain)           |
| 2. Intermediate Control Pan | 4. Drive Unit  | 6. Enlarge Holes (4 Places ONLY) |

## Installing the Auger Tube

### Assembly

1. Inspect the tubes to make sure that the tabs at each dropout hole are bent 90 degrees outward.
2. Install the pan assemblies onto the tube as described in your specific pan installation guide.
3. Place the tube sections on the floor directly under the main cable in their approximate location.



**IMPORTANT! The belled end of the tube must face the hopper.**

4. Connect the tubes together, starting at the hopper end, by sliding the belled end of one tube over the straight end of the next tube.
  - Connect the tubes so that the small hole on the belled end of the tube faces upward to make sure that the feed dropout holes are at the bottom of the tube.
5. Strike the end of each tube section with a mallet in order to seat the tube ends. Protect the end of the tube with a block of wood.

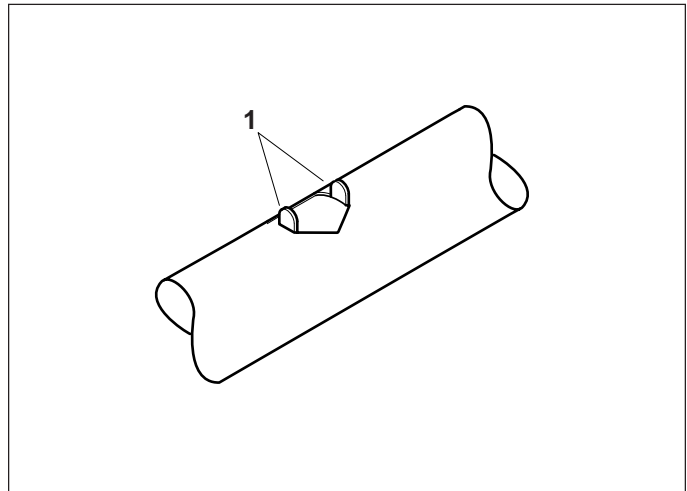

*Inspect the tube tabs.*

1. *1. Tabs should be bent 90 degrees outward.*

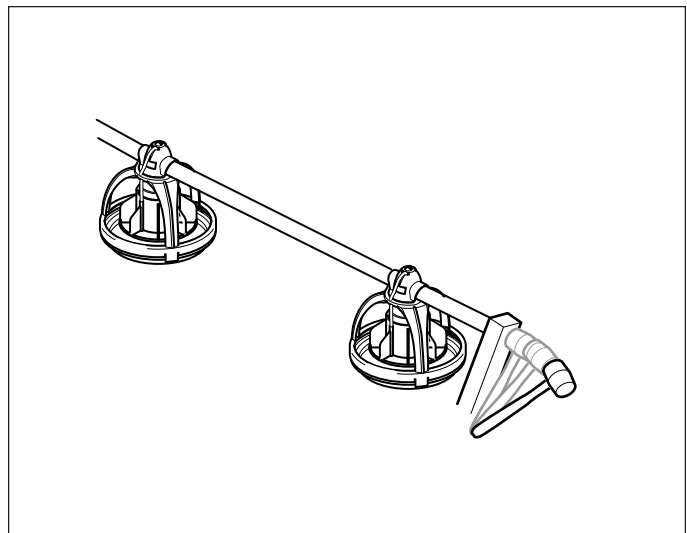

*Strike the ends of each tube section to seat the tube ends.*

5. Install tube clamps at each tube joint.

- There is a small hole on the belled end of each auger tube. The tube clamp must be installed so that it touches this hole.

**Note:** Do not tighten the tube clamps until after the feed line is suspended.

*When you are installing clamps at the hopper or drive unit:*

- Install two clamps at these locations to provide additional support.

*If you have a swinging pan system:*

- Install u-bolt tube clamps or split clamps to connect each tube to the next.
- Install hanger bails for suspending the feed line no more than 10 ft. [3m] apart.

*If you have a fixed pan system:*

- Install split-clamps to connect each tube to the next.
- Install a stabilizer clamp near every third tube joint, no more than 30 ft. [9m] apart.
- Install a stabilizer clamp assembly near the joint just before the drive unit.

**Note:** Stabilizer clamps are not to be used as joint clamps. Stabilizer clamps are used to suspend a fixed pan feed line.

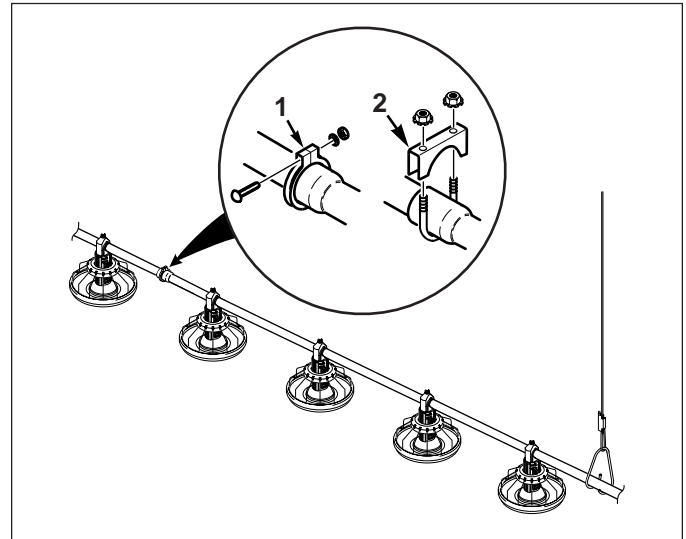

**Install a clamp at every tube joint.**

1. Split Clamp
2. U-bolt Clamp (do not use on fixed pan system)

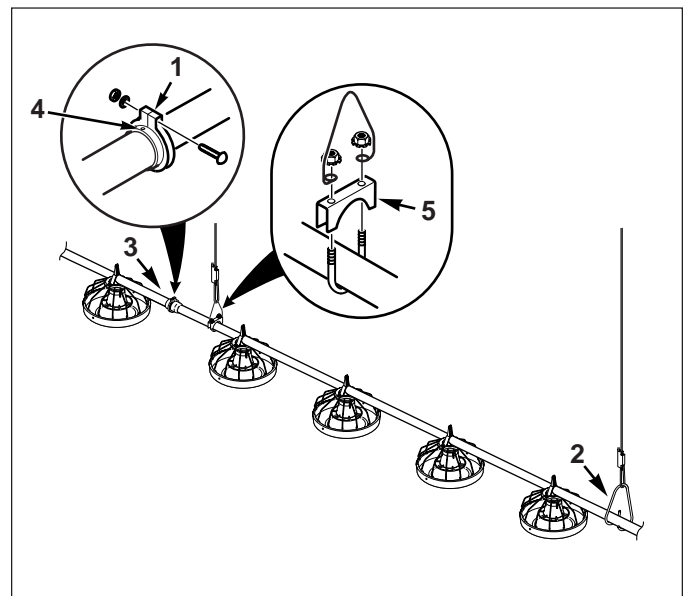

**Connect the auger tubes together with clamps and suspend the feed line.**

1. Split Clamp
2. Hanger Bail
3. Tube Joint
4. Top of Tube
5. Stabilizer Clamp

## Suspending the Feeding Line

1. Install hanger bails on the tubes at the locations where the drop cables hang down.
2. Feed the suspension drop cables through the tube hanger bails as described in the Suspension Equipment Installation Guide.
3. Secure the cables with cable locks.
4. Level the entire feeder line by adjusting the cable locks.

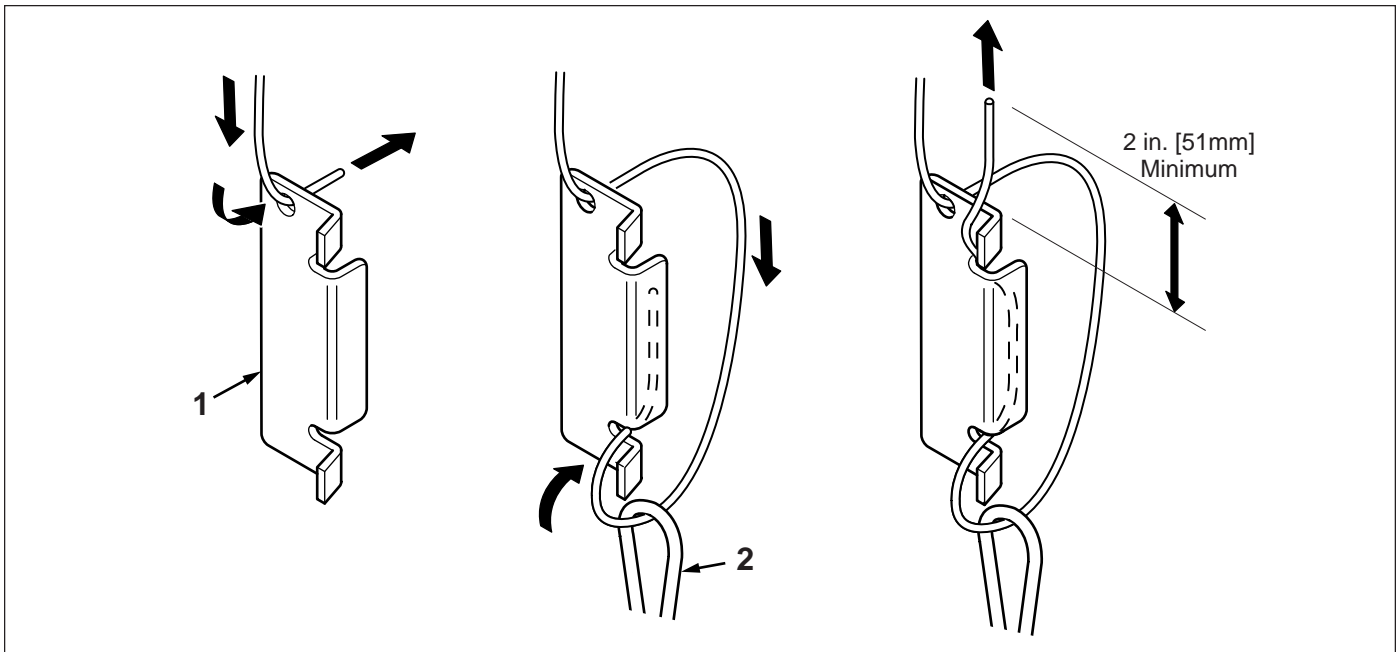

**STEP ONE:**  
*Insert Cable  
through Hole*  
1. Cable Lock

**STEP TWO**  
*Loop Cable  
through Hanger,  
then up to  
bottom slot*  
2. Hanger

**STEP THREE:**  
*Pull Cable up  
through top slot*



## Installing the Auger



**WARNING!** Be very careful when stretching auger. If the auger should get loose, never try to stop it, let it go. Never get your fingers tangled in the auger when it can move in the tube.

### Preparation

1. Remove the arbor from the hopper.
2. Place the coil of auger several feet from the hopper end of the line.
3. Stand about 3 ft. [1m] away from the hopper.

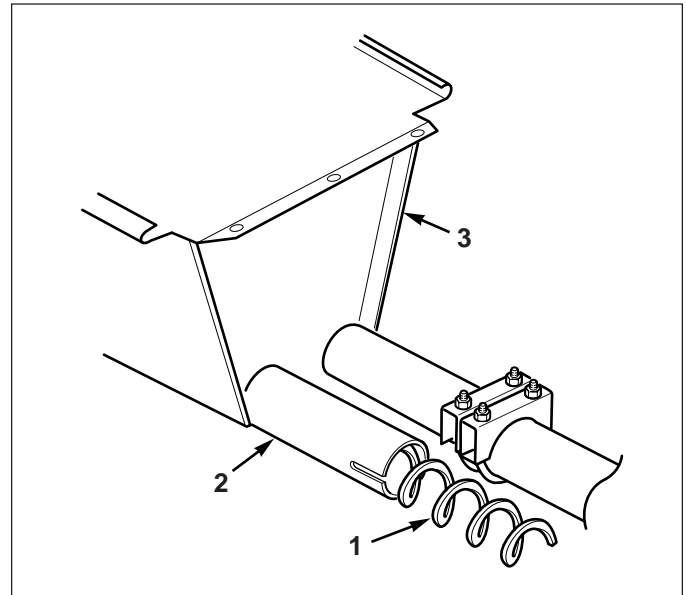

*Feed the auger into the hopper tube.*

- |                |           |
|----------------|-----------|
| 1. Auger       | 3. Hopper |
| 2. Hopper Tube |           |

### Installation

1. Feed the auger into the hopper tube.
  - Be careful not to kink the auger. If the auger kinks, refer to the section of this manual on auger brazing.
2. Feed the auger into the tube until it reaches the drive unit.
3. Attach the auger securely to the drive arbor.
  - Thread the end of the auger through the auger clamp.
  - Tighten the screw to hold the auger in place.
4. Mark the auger at the point it enters the hopper.

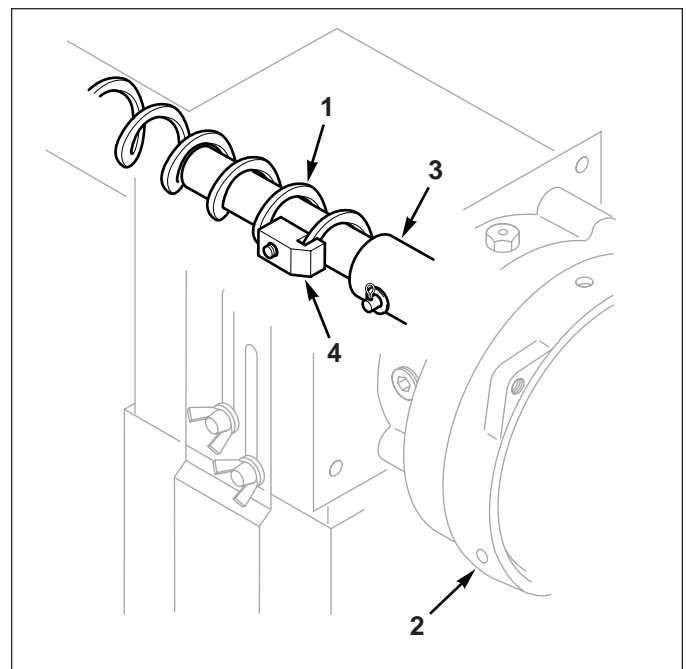

*Attach the auger to the drive unit arbor assembly.*

- |               |  |
|---------------|--|
| 1. Auger      | 3. Arbor Assembly                            |
| 2. Drive Unit | 4. Thread the Auger through the Auger Clamp. |

5. Stretch the auger by pulling it 7 in. [180mm] for every 10 auger tubes in the line. Mark this location on the auger for cutting.
  - Stretch the auger another 1 ft. [300mm] so that you have room to install the hopper bearing assembly.
  - Clamp the auger at the hopper with locking pliers.
  - Allow the locking pliers to rest against the hopper boot to prevent the auger from relaxing.
  - Cut the auger at the mark you made earlier (a cutting torch works best).
  - File all rough edges of the auger.

**WARNING!** Be very careful when stretching auger. If the auger should get loose, never try to stop it, let it go. Never get your fingers tangled in the auger when it can move into the tube.

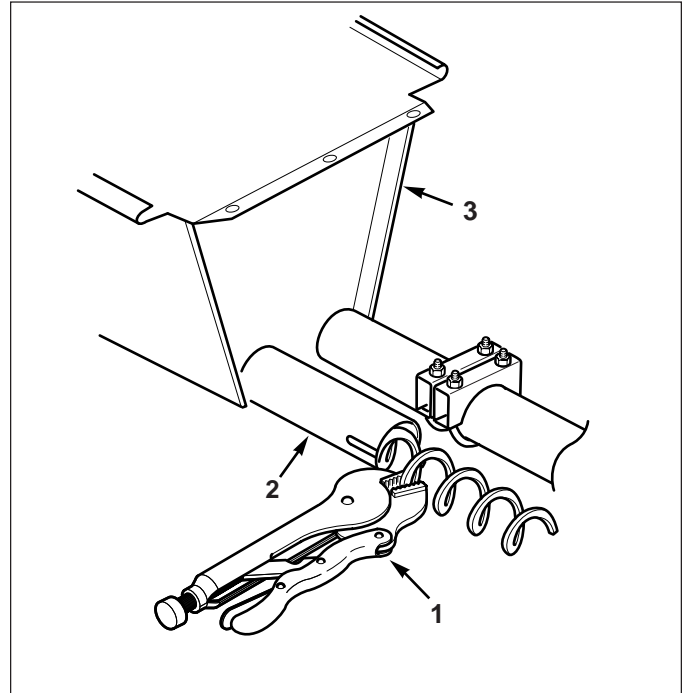

**Clamp the auger with locking pliers to prevent it from relaxing.**

- |                   |           |
|-------------------|-----------|
| 1. Locking Pliers | 3. Hopper |
| 2. Hopper Tube    |           |

6. Attach the hopper arbor assembly to the auger.
  - Insert the hopper arbor assembly into the auger.
  - Thread the auger through the clamp until the end of the auger touches the stop of the arbor assembly.
  - Tighten the set screw to secure the arbor tightly onto the assembly.
  - Carefully release the auger into the hopper boot.
  - Tighten the U-bolt clamp to secure the arbor assembly.

**CAUTION:** Do not overtighten this clamp. If you overtighten, servicing the bearing will be difficult.

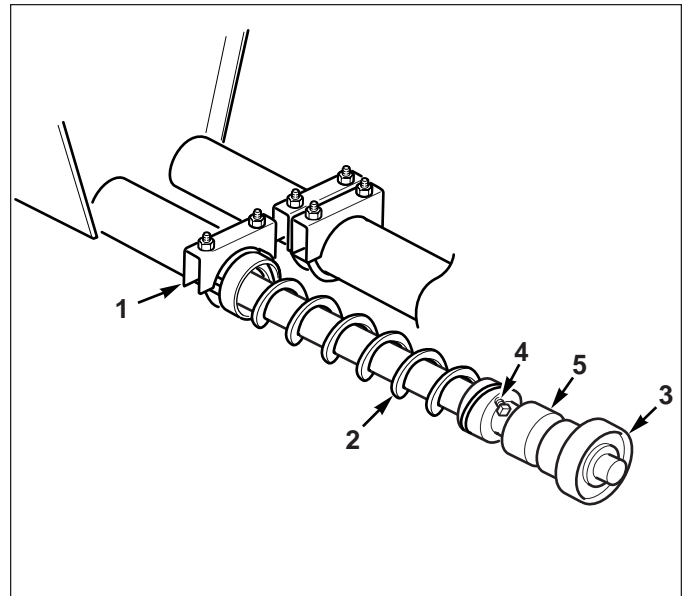

**Attach the auger to the hopper boot bearing assembly.**

- |                 |                           |
|-----------------|---------------------------|
| 1. U-bolt Clamp | 3. Hopper Arbor assembly  |
| 2. Auger        | 4. Set screw              |
|                 | 5. Auger end against Stop |

6. Place the feed agitating ball in the hopper boot.

## Brazing the Auger

Big Dutchman auger is made of a specially hardened steel that requires specific procedures during the brazing process. Carefully follow the instructions below to assure a strong, smooth joint.

### Preparation

1. File both ends of the auger smooth. Clean the oily coating from the last full turn of auger.
2. Align and clamp the two auger ends on a length of angle iron.
3. Butt the two ends of the auger approximately half a turn.



**CAUTION: Do not hook the ends of the auger inside each other. Do not butt more than 3/4 of a turn of auger.**

### Brazing

1. Braze the auger joint, keeping the heat low. Uniformly heat the first two full turns of auger, one turn in each direction from the joint.

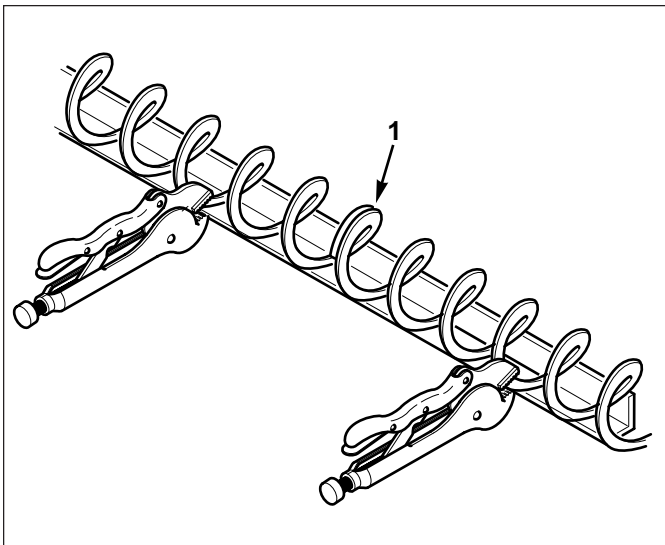

**Braze the auger to attach the two pieces together.**  
1. Braze Joint

2. Heat the brazing rod tip and dip it in the flux while continuing to heat the auger to nearly white hot. Apply brazing rod.

- The near white heat stage should allow the brazing material to flow into the joint.



**CAUTION: Do not apply unnecessary amounts of rod. Excessive material on the auger will interfere with the flow of feed.**

3. Reheat the area uniformly to cherry red after the brazing is completed. Cool the auger with boiling water.
4. Temper the brazed area to complete the brazing process.
  - Uniformly reheat the two-turn area for a short time (to a straw color). This will return the spring to the auger.



**CAUTION: Do not overheat the auger during this process. Too much heat at this point will soften the steel. If the auger is overheated during this process, repeat the tempering process.**

5. Allow the auger to air-cool.
6. Grind off burrs and high spots inside and outside of the welded area.

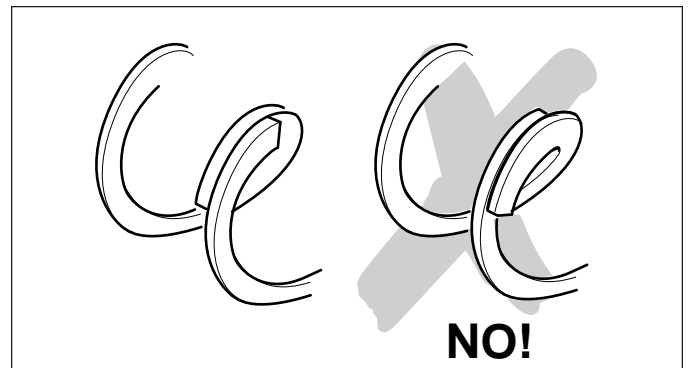

**Butt the ends of the auger together. Do not overlap the ends of the auger!**

## Installing Anti-Perch

### Installation

Big Dutchman uses two kinds of anti-perch equipment for its auger feeding systems: the high-tensile anti-perch wire and winch system (used with UniGROW 360 components *only*) and the universal anti-perch system. If you are installing a UniGROW 360 auger feeding line, please refer to the UniGROW Pan Installation Manual for anti-perch installation instructions.

### Components

*Anti-Perch Cable* – Spans across the auger tube and prevents birds from roosting on the line.

*End Anchor Kit* – Includes insulators, brackets, clamps, and the necessary hardware to install the end anchors at the drive unit and hopper.

*Spring Kit* – Connects cables every 10 tubes in the feeder line.

*Electrocharger* – Supplies electric power to the anti-perch system.

**Note:** The Control Pan features an anti-perch wire which must be installed on the insulators on top of the Control Pan prior to installing the anti-perch equipment.

To install your anti-perch system:

1. Begin at the Drive or Hopper end.
2. Use one of the double U-bolt clamps to install the anchor bracket.
3. Insert the support bracket through the U-bolt and reattach the U-Bolt bracket to the auger tube.
4. Insert the insulator between arms of the support bracket. Move the insulator to the desired height, threading the bolt through the insulator and the holes on the bracket. Secure in place with the nut.

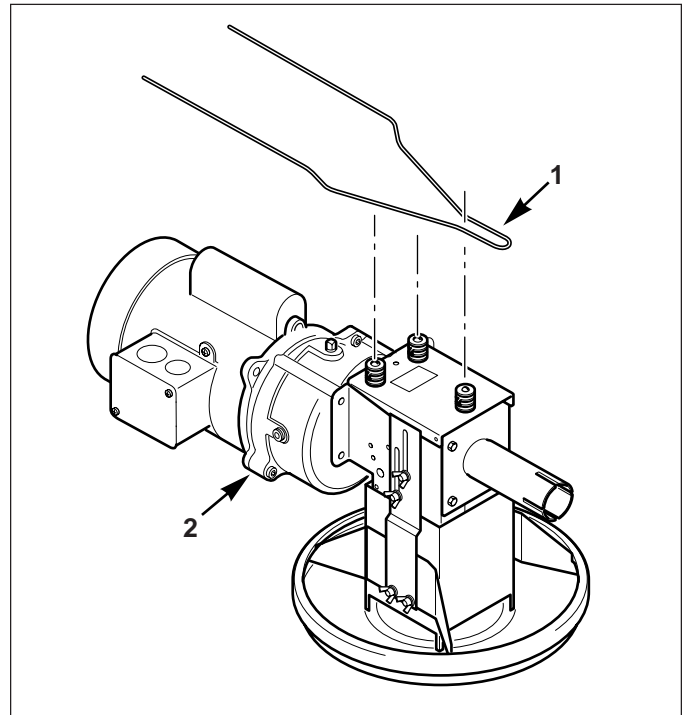

**Attach the anti-perch wire to the insulators on the top of the control pan.**

1. Anti-Perch Wire

2. Control Pan/Drive Unit Assembly

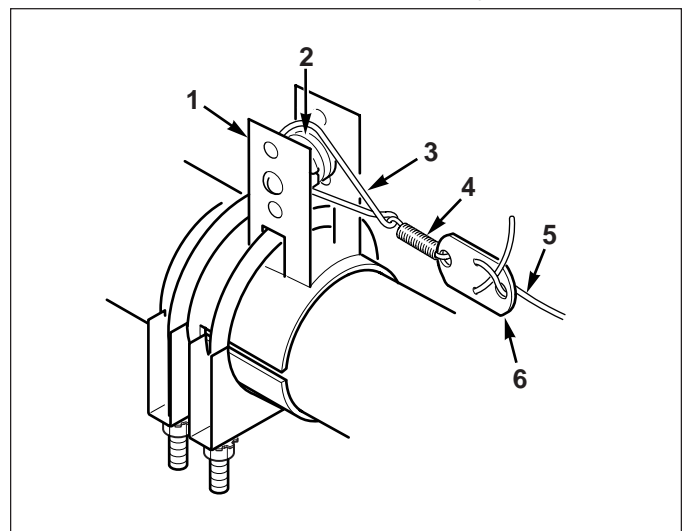

**Assemble and install the anti-perch end kit.**

1. Support Bracket

4. Spring

2. Insulator

5. Anti-Perch Cable

3. Tie Wire

6. Cable Lock

5. Attach the tie wire to the insulator, pinching the curled ends of the wire together. Install one end of a spring onto the two wire ends, and insert a cable lock onto the other end of the spring.
6. Thread the end of a length of cable (approx. 100 ft. [30m]) through the cable lock.
7. Pull the other end of the cable across the length of the feed line toward the opposite end of the feeding system. Some pans provide a hole that the cable is threaded through.
8. Install a spring kit every 10 tubes.
  - Thread the loose end of the cable through a cable lock. Attach the other side of the cable lock to a spring.
  - Cut another length of cable (approx.. 100 ft. [30m]) and thread one end of the cable through another cable lock.
  - Attach the free end of the cable lock onto the spring.
9. Continue to pull the loose end of the cable across the length of the feed line, installing a spring kit every 10 tubes.
10. Attach the cable to the End Anchor Kit at the other end of the feed line. Stretch cable about 1 to 1 1/2 in. [25 to 35 mm] before tightening the cable clamp.

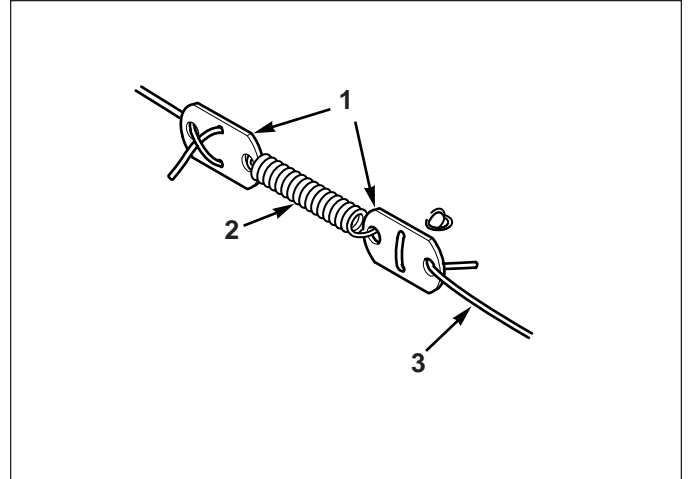

**Install a spring kit every 10 tubes.**

- 1. Cable Locks**
- 2. Spring**
- 3. Anti-Perch Cable**

# Finishing, Testing and Start-up Operation

## Check Suspension

1. Raise the feeding system several feet to see that the entire line moves in the same direction and that it remains level.
  - Raise and lower the system several times.
  - Watch for any binding or unusual noises.
  - Make sure that the Feed Drop Tube that supplies the feed to the hopper remains in the proper operating position at all times.

## Final Checks

1. Check the drive unit end of the feeder line.
  - The power cord to the motor should be secured and not allowed to dangle.
  - The anti-perch wire should not touch any metal object.
  - The jumper wire must be installed.
  - Make sure that the anti-perch spring is not touching any part of the bracket and that it is properly seated in the insulator.
2. Check all tube clamps - they should be tight, but should not crush the tube.
  - Check the clamps at the drive end and at the hopper end to make sure that they are secure.

## Test Feeder and Drive Units

1. Make sure that drive is plugged in.
2. Turn on power to the feed lines.
  - Make sure feeders are turning in the proper direction.
  - Allow the feeders to run dry for 15-20 minutes. This will deburr the inside of the tube, and make the system run smoothly. The system will make noise, this is normal.
3. Empty feed pans of any material that has collected.

## Start-up Operation

1. Raise the feed line enough to prepare the litter.
  - Once the floor is prepared, lower the feed line to the floor.
  - Let the pans touch the floor, but do not allow the drive and hopper ends to hang lower than their normal level position.
2. Turn on power to the fill system to fill the hoppers.
  - Turn on the power to the feed line.
  - Feed will spill into the first pan when the drive unit begins to run. The rest of the pans will continue to fill until the drop in the control pan is full. The control pan should shut off the drive motor.
3. Prepare for the arrival of the new chicks.
  - It is normal for the control pan to have less feed in it than the rest of the pans. This allows the control pan to call for feed more frequently so that the other pans are kept full.

## Big Dutchman, Inc. Limited Warranty

1. Big Dutchman warrants to the original purchaser that as to any product of its manufacture proving to be defective in material or workmanship under normal and intended use and service within one year from date of purchase thereof Big Dutchman will, at its option, (a) repair or replace such product free of charge, or (b) in lieu of repair or replacement, refund to the original purchaser the original purchase price less the reasonable value of the product's use to the original purchaser.
2. Any component parts that are not manufactured by Big Dutchman, such as electrical motors and controls, are excluded from this warranty, although such parts may be covered by separate warranties of the respective manufacturers. Copies of those other warranties, if any, may be obtained through Big Dutchman.
3. This warranty does not apply if all components of a system are not supplied by Big Dutchman, or if the product is not purchased from and installed by an authorized Big Dutchman distributor or company warehouse, or installed and operated in accordance with Big Dutchman specifications and instructions.
4. This warranty does not cover malfunctions or failures resulting from misuse, abuse, negligence, alterations, unauthorized or improper repairs, accident, damage while in transit, or lack of authorized or proper maintenance or installation. In addition, this warranty does not cover normal wear and tear or any problem with a product not caused by a defect in Big Dutchman materials or workmanship.
5. The obligations of Big Dutchman under this warranty do not include shipping charges, labor (whether for dismantling, installing, replacing or repairing), travel and subsistence allowance.
6. This warranty applies only to systems for the care of poultry and livestock. It does not apply to industrial or commercial installation. In addition, with respect to Big Dutchman's breeder nest system, Big Dutchman makes no warranty or guarantee that individual birds or any given population of birds will utilize the nests.
7. Warranty claims must be made in writing to Big Dutchman within 20 days of discovery and in accordance with Big Dutchman's published return-goods procedures, a copy of which may be obtained from Big Dutchman. For this warranty to apply, the product must be returned to a facility specified by Big Dutchman, freight prepaid and insured with proof of original purchase and date.
8. The acceptance by Big Dutchman of any product for repair, replacement or refund will not be deemed an admission by Big Dutchman that the product is defective or in violation of any warranty. Products that are replaced or for which a refund is issued become the property of Big Dutchman.
9. The rights and obligations of the purchaser under this warranty may neither be assigned nor delegated without the prior written permission of an authorized officer of Big Dutchman.
10. This warranty contains the entire warranty agreement between Big Dutchman and the purchaser, and the terms and conditions of this warranty supersede any and all other understandings, representations or proposals between Big Dutchman and the purchaser with respect to the matters covered by this warranty. This warranty shall not be modified by any custom or practice of the trade or of the parties, nor by any instances of Big Dutchman's waiver of or failure to enforce any of the provisions of this warranty.
11. This warranty may be modified or amended only in writing signed by both the purchaser and an authorized officer of Big Dutchman, and no other agent, employee, salesman, representative, dealer or distributor is authorized to make or to bind Big Dutchman to any representation, affirmation or warranty concerning the products in any manner whatsoever.
12. If Big Dutchman fails to fulfill its obligations in this warranty, or if Big Dutchman is determined to be liable to the purchaser or any other person for any reason related to any product covered by this warranty or the sale of that product, the maximum amount of damages, whether arising out of tort, contract, negligence or otherwise, recoverable from Big Dutchman by the purchaser shall be limited to the purchase price of the product with respect to which Big Dutchman's obligations or liability arises, less the reasonable value of the product's use to the purchaser.
13. THE OBLIGATIONS AND LIABILITIES OF BIG DUTCHMAN AND THE RIGHTS AND REMEDIES OF THE PURCHASER UNDER THIS WARRANTY ARE EXCLUSIVE AND IN LIEU OF ALL OTHER WARRANTIES, GUARANTEES, OBLIGATIONS, LIABILITIES, RIGHTS AND REMEDIES, EXPRESSED OR IMPLIED, ARISING BY LAW OR OTHERWISE, INCLUDING BUT NOT LIMITED TO THE IMPLIED WARRANTY OF MERCHANTABILITY, THE IMPLIED WARRANTY OF FITNESS FOR A PARTICULAR PURPOSE, AND ANY IMPLIED OR EXPRESSED WARRANTY ARISING FROM THE COURSE OF PERFORMANCE, COURSE OF DEALING OR USAGE OR TRADE. BIG DUTCHMAN SHALL HAVE NO OBLIGATION OR LIABILITY, WHETHER UNDER THIS WARRANTY OR OTHERWISE, FOR INCIDENTAL, CONSEQUENTIAL OR SPECIAL DAMAGES, LOST PROFITS, REVENUE OR OTHER INCOME, LOSS OF USE, DAMAGES FOR INJURY TO PERSONS OR PROPERTY, OR ANY OTHER DAMAGES.
14. Some states do not allow limitations on how long an implied warranty lasts or the exclusion or limitation of incidental or consequential damages, so the above limitations and exclusions may not apply to each purchaser. This warranty gives the purchaser specific legal rights, and the purchaser may have other rights that vary from state to state.



# Big Dutchman

### **Germany**

P.O. Box 11 63 · D-49360 Vechta · Germany  
tel +49 (0) 44 47 801 0 · fax +49 (0) 44 47 801 237  
www.bigdutchman.com · big@bigdutchman.de

### **Asia-Pacific**

No. 25 Jalan Pemberita (U1/49), Temasya Industrial Park  
40150 Shah Alam · Selangor Darul Ehsan · Malaysia  
tel +603 5569 2320 · fax +603 5569 5930  
bdasia@bda.com.my

### **USA**

P.O. Box 1017 · Holland, MI 49422-1017 · USA  
tel +1 616 392 5981 · fax +1 616 392 6188  
www.bigdutchman.com · bigd@bigdutchmanusa.com

### **Brazil**

Caixa Postal 84 · Rua Victorio Milani, 125  
Caxias do Sul, RS 95095-107 · Brasil  
tel +55 (0) 54 226 2200 · fax +55 (0) 54 226 1424  
www.bigdutchman.com.br · bigdutchmanbrasil@bigdutchman.com.br